

Vibration Test System TV 50009

DESCRIPTION

TIRA permanent magnet shakers are applicable as portable and stationary systems for reproducing environmental effects.

Typical fields of applications are modal excitation and analyses, structural testing, calibration of sensors and testing of small components. The rugged design of the shakers guarantees their long operating life. TIRA shakers stand for such features like a high lateral and axial stiffness.

TIRA have realized the light-weight design of shakers required by the industry. New rare-earth magnets replace the alnico magnets used up to now. Thus, a weight reduction from 30 kg (66 lb) to 10 kg (22 lb) could be achieved which enables an easy shaker-handling especially for mobile applications as "one man" excitation source.

These shakers have turned out to be outstanding in fields of applications such as environmental laboratories, universities and industrial production lines for testing components and for in-house calibration. This line of shakers enables the user to carry out tests in accordance with national and international standards such as DIN, ISO, BS, MIL, IEC ...



AMPLIFIER BAA 60

KVA ratings	60 VA
Frequency range	DC-20 kHz
Voltage, max.	16 V
Current, max.	3.8 A
Load resistance	4 Ohm
Input voltage	< 5 V
Distortion	< 0.1 %
Signal to noise Ratio	> 90 dB
Weight	12 kg (26.5 lb)
Size (WxHxD)	483 x 90 x 450 mm (19 x 3.5 x 17.7 in)



TECHNICAL SPECIFICATION VIBRATION GENERATOR S 50009

Rated peak force (N lbf)	Sine	9	2
Frequency range (Hz)		2-18000	2-18000
Max. rated travel (mm inch)	Pk-Pk	3	0.12
Max. velocity (m/sec inch/sec)	Sine	1.5	59
Max. acceleration (g)	Sine	60	60
Max. power consumption at 230 V (kVA)		0.05	0.05
Nominal impedance (Ohm)		4	4
Suspension stiffness (N/mm lbf/inch)		4	22.8
Effective moving mass (kg lb)		0.015	0.033
Main resonance frequency (Hz)		> 16000	> 16000
Weight with/without trunnion (kg lb)		2.2/1.7	4.9/3.7
Armature (ø/mm ø/inch)		7	0.28

PERFORMANCE DIAGRAM

System Performance TV 50009

Force: 9 N max. Acceleration: 60 g max. Velocity: 1,5 m/s max. Displacement: 3 mm

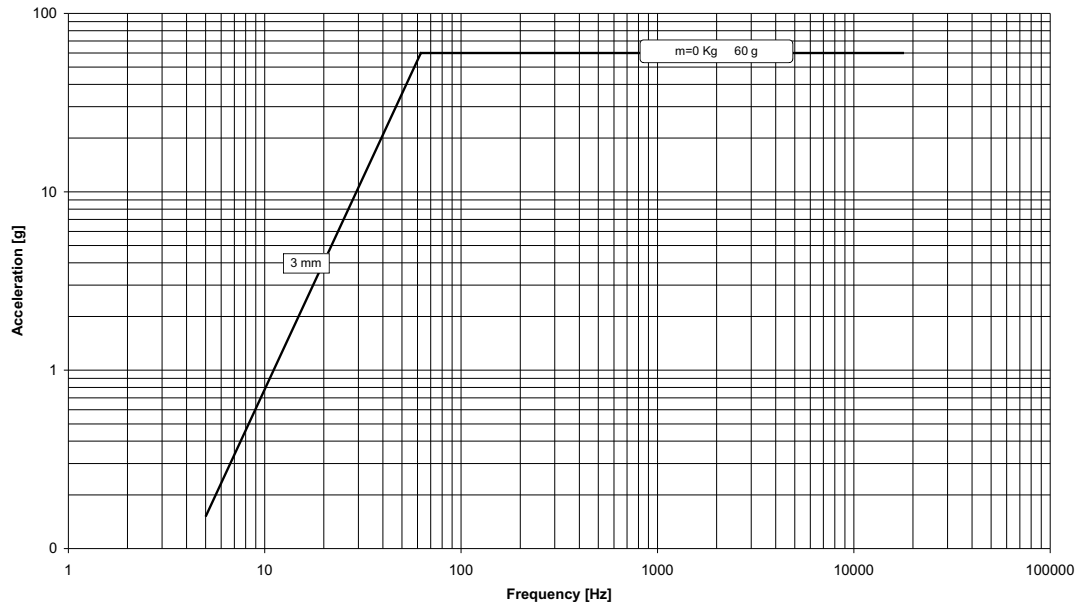

DIMENSIONS in mm

S 50009 (Example drawing)

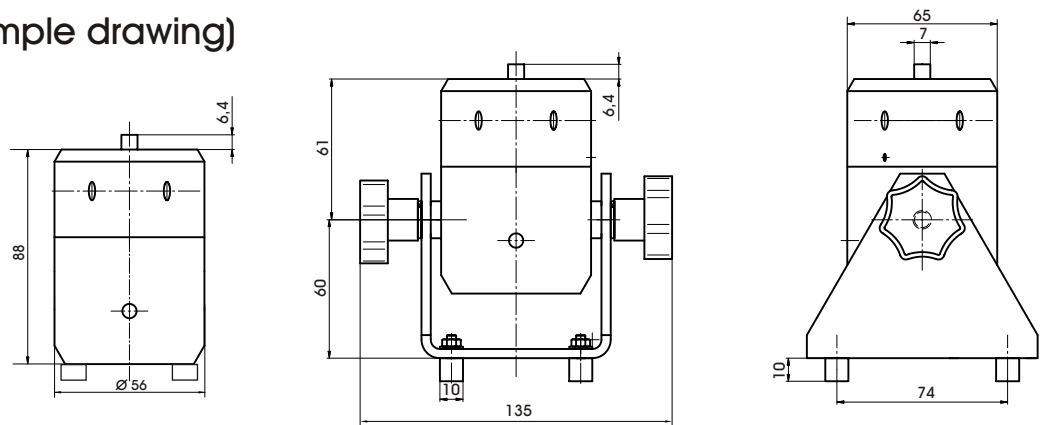

Subject to modifications

TIRA GmbH

96528 Schalkau Eisfelder Str. 23-25 Germany Tel.: +49 36766 280-0 Fax: +49 36766 280-99

Internet: www.tira-gmbh.de

e-mail: st@tira-gmbh.de